

**PURPOSE**

4VAC50-60-54 of the Virginia Stormwater Management Program (VSMP) Permit Regulations requires that Stormwater Pollution Prevention Plan (SWPPP) be developed for all regulated land disturbing activities. The SWPPP must include, but not be limited to, an approved erosion and sediment control plan, an approved stormwater management plan, and this **Pollution Prevention Plan (PPP)** for regulated land disturbing activities, and a description of any additional control measures necessary to address a TMDL as applicable.

The plan for implementing pollution prevention measures during construction activities developed on this sheet must be implemented and updated as necessary. Any PPP requirements not included on this sheet must be incorporated into the SWPPP required by 4VAC50-60-54 that must be developed before land disturbance commences. This PPP identifies potential sources of pollutants that may reasonably be expected to affect the quality stormwater discharges from the construction site (both on- and off-site activities) and describes control measures that will be used to minimize pollutants in stormwater discharges from the construction site.

**OTHER REFERENCED PLANS**

SWPPP requirements may be referenced by incorporating, by reference, other plans. All plans incorporated by reference become enforceable under the VSMP Permit Regulations and General Permit VAR10 for Discharges of Stormwater from Construction Activities. If a plan incorporated by reference does not contain all of the required elements of the PPP, the operator must develop the missing elements and include them in the SWPPP.

Independent Plans Incorporated by Reference	Date Approved
Stormwater Management Plans (Regional or Master)	N/A
Spill Prevention, Control, and Countermeasure Plans	N/A
Off-Site Stockpile	N/A
Off-Site Borrow Area	N/A

**POTENTIAL POLLUTANT SOURCES**

The following sources of potential pollutants must be addressed in the Pollution Prevention Plan. Various controls and/or measures designed to prevent and/or minimize pollutants in stormwater discharges from the project site must be applied to the sources found on the site. Additional information concerning the following controls and/or measures may be found in the SWPPP. Deviations from the location criteria may be approved by the Henrico County Environmental Inspector.

**LEAKS, SPILLS, AND OTHER RELEASES**

- The operator(s) shall ensure procedures are in place to prevent and respond to all leaks, spills and other releases of pollutants.
- The operator(s) shall ensure all leaks, spills and other releases of pollutant are contained and cleaned immediately upon discovery. Any contaminated materials are to be disposed in accordance with federal, state, and/or local requirements.
- The operator(s) shall ensure spill containment kits containing appropriate materials (e.g., absorbent material and pads, brooms, gloves, sand, etc.) are available at appropriate locations, including, but not limited to designated areas for vehicle and equipment maintenance, vehicle and equipment fueling, storage and disposal of construction materials, products, and waste, and storage and disposal of hazardous and toxic materials, and sanitary waste facilities.
- The locations of the spill containment kits are identified as described below.

Date	Shown on Plan Sheet # (s)	Location	
Approved Plan	2D(8)	Location No. 1	
REVISIONS TO LOCATIONS			
Date	Shown on Plan Sheet # (s)	Location	Operator(s) Initials

- The operator(s) shall notify the Department of Environmental Quality of leaks, spills, and other releases that discharge to or have the potential to discharge to surface waters immediately upon discovery of the discharge but in no case later than 24 after the discovery.
- The operator(s) shall notify the Department of Environmental Quality (DEQ) of leaks, spills, and other releases that discharge to or have the potential to discharge to surface waters immediately upon discovery of the discharge but in no case later than 24 after the discovery. Written notice of the discharge must be sent to DEQ and Henrico County Department of Public Works within five (5) days of the discovery.

Virginia Department of Environmental Quality NEED ADDRESS (804) 786-3998 (phone) (804) 786-1798 (fax) (800) 468-8892 (outside normal working hours)	Henrico County Department of Public Works P. O. Box 90775 Henrico, VA 23273 (804) 501-4393 (phone) (804) 501-7475 (fax)
---	---

**EQUIPMENT / VEHICLE WASHING**

- Washing must be conducted in a **dedicated area** that is located to maximize the distance from storm drain inlets, ditches, waterbodies or wetlands but no less than 50 feet from those features.
- All wash water used in vehicle wheel washing must be directed to a sediment basin/trap.
- All vehicle washing activities other than wheel washing must have secondary containment.
- Each facility must have appropriate signage to inform users where the **dedicated area(s)** are located.

Activity	Location of Dedicated Area(s)	Shown on Plan Sheet # (s)	Water Source Location	
Wheel Wash	Location No. 2	2D(7)	Location No. 2	
Other Wash Areas				
REVISIONS TO LOCATIONS				
Activity	Location of Dedicated Area(s)	Shown on Plan Sheet # (s)	Water Source Location	Operator's Initials

**VEHICLE FUELING AND MAINTENANCE**

- Conduct regular maintenance in a **dedicated area** that is located to maximize the distance from storm drain inlets, ditches, waterbodies or wetlands but no less than 50 feet from those features.
- If fueling is conducted at a **dedicated area**, the location must be located to maximize the distance from storm drain inlets, ditches, waterbodies or wetlands but no less than 50 feet from those features.
- The **dedicated areas** must be designed to eliminate the discharge of spilled and leaked fuels and chemicals from vehicle fueling and maintenance activities by providing secondary containment (spill berms, decks, spill containment pallets, providing cover where appropriate, and having spill kits readily available).
- Each facility must have appropriate signage to inform users where the **dedicated area(s)** are located.

Date	Shown on Plan Sheet # (s)	Location of Dedicated Area(s)	
Approved Plan	2D(8)	Location No. 3	
REVISIONS TO LOCATIONS			
Date	Shown on Plan Sheet # (s)	Location of Dedicated Area(s)	Operator's Initials

- If mobile fueling will be used, the fueling must be done in an area that located to maximize the distance from storm drain inlets, ditches, waterbodies or wetlands but no less than 50 feet from those features.
- Spill kits must be readily available at all mobile fueling locations.
- On-site storage tanks must have a means of secondary containment (spill berms, decks, spill containment pallets, etc.) and must be covered where appropriate.
- All vehicles on site must be monitored for leaks and receive regular preventive maintenance to reduce the chance of leakage.

**DISCHARGE FROM STORAGE, HANDLING, AND DISPOSAL OF CONSTRUCTION PRODUCTS, MATERIALS, AND WASTE**

- Storage of construction products, materials, and waste is to be conducted in **dedicated areas**.
- The **dedicated area** must be located to maximize the distance from storm drain inlets, ditches, waterbodies or wetlands but no less than 50 feet from those features. Separations of less than 50 feet may be approved by the Environmental Inspector.
- The **dedicated areas** must be designed to minimize the discharge of pollutants from storage, handling, and disposal of construction products, materials and wastes including (i) building products such as asphalt sealants, copper flashing roofing materials, adhesives, concrete admixtures, (ii) pesticides, herbicides, insecticides, fertilizers, and landscape materials, and (iii) construction and domestic wastes such as packaging materials, scrap construction materials, masonry products, timber, pipe and electrical cuttings, plastics, Styrofoam, concrete and other trash or building products.
- Each facility must have appropriate signage to inform users where the **dedicated area(s)** are located.

Date	Shown on Plan Sheet # (s)	Location(s) of Dedicated Area(s) for storage of construction products and materials	
Approved Plan	2D(8)	Location No. 4	
REVISIONS TO LOCATIONS			
Date	Shown on Plan Sheet # (s)	Location(s) of Dedicated Area(s) for storage of construction products and materials	Operator(s) Initials

Date	Shown on Plan Sheet # (s)	Location(s) of Dedicated Area(s) for waste from construction products and materials	
Approved Plan	2D(8)	Location No. 4	
REVISIONS TO LOCATIONS			
Date	Shown on Plan Sheet # (s)	Location(s) of Dedicated Area(s) for waste from construction products and materials	Operator(s) Initials

- Follow all federal, state, and local requirements that apply to the use, handling and disposal of pesticides, herbicides, and fertilizers.
- Keep chemicals on-site in small quantities and in closed, well marked containers.
- Clean up solid waste, including building materials, garbage, and debris on a daily basis and deposit into covered dumpsters that are periodically emptied.
- Schedule waste collection to prevent exceeding the capacity of onsite containers. Additional containers may be necessary depending on the phase of construction (e.g., demolition, etc.).
- Dispose of all solid waste at an authorized disposal site.
- Ensure that containers have lids or are otherwise protected from exposure to precipitation.

**DISCHARGES FROM OTHER POTENTIAL POLLUTANT SOURCES**

Other Potential Pollutant Sources	Location(s) of Potential Pollutant Sources

- Above ground oil storage tanks with a storage capacity exceeding 1,320 gallons and have a reasonable expectation of a discharge into or upon Waters of the United States are required to have a Spill Prevention Control and Countermeasure (SPCC) Plan.
- The discharge of contaminated flush water and material removed during flushing operations must be collected and disposed of in accordance with appropriate federal, state, and local requirements.

**DISCHARGES FROM CONCRETE RELATED WASH ACTIVITIES**

- Concrete trucks are not allowed to wash out or discharge surplus concrete or drum wash water on site except in a **dedicated area(s)** that is located to prevent discharge to storm drain inlets, ditches, waterbodies or wetlands but no less than 50 feet from those features.
- Each facility must have a stabilized access to prevent mud tracking into the street.
- Each facility must have appropriate signage to inform users where the **dedicated area(s)** are located.

Date	Shown on Plan Sheet # (s)	Location of Dedicated Area(s)	
Approved Plan	2D(7)	Location No. 5	
REVISIONS TO LOCATIONS			
Date	Shown on Plan Sheet # (s)	Location of Dedicated Area(s)	Operator's Initials

- Facilities must be cleaned, or new facilities constructed, once the washout area is two-thirds (2/3) full.

**BELOW GRADE CONCRETE WASHOUT AREA**

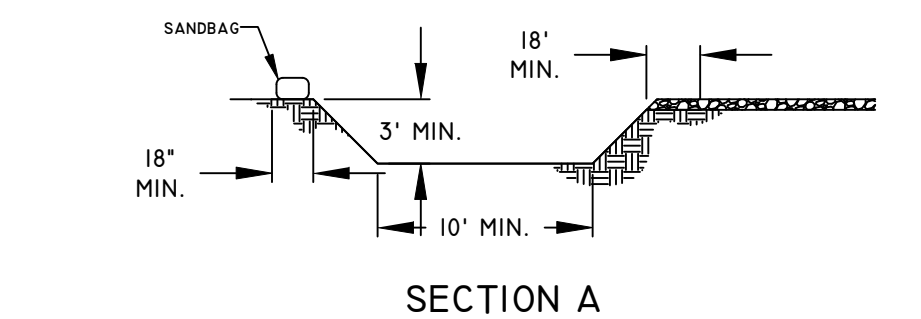
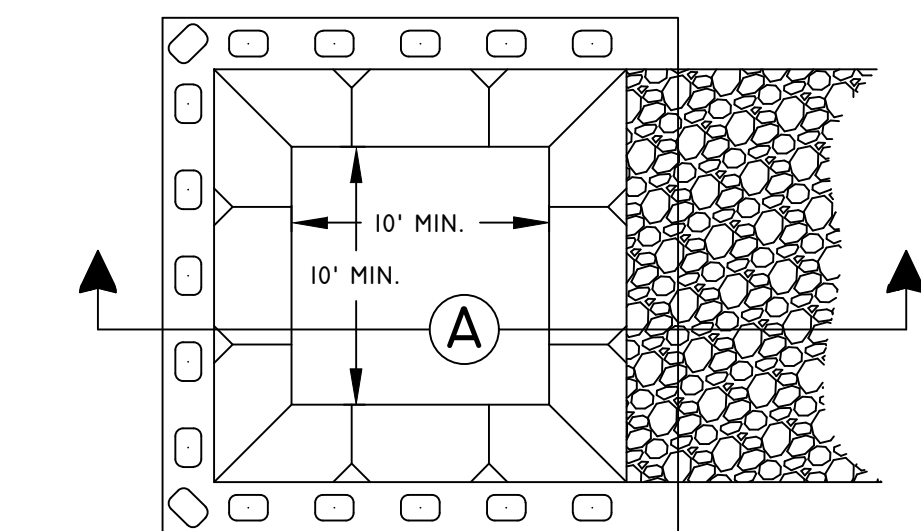

**ABOVE GRADE CONCRETE WASHOUT AREA**

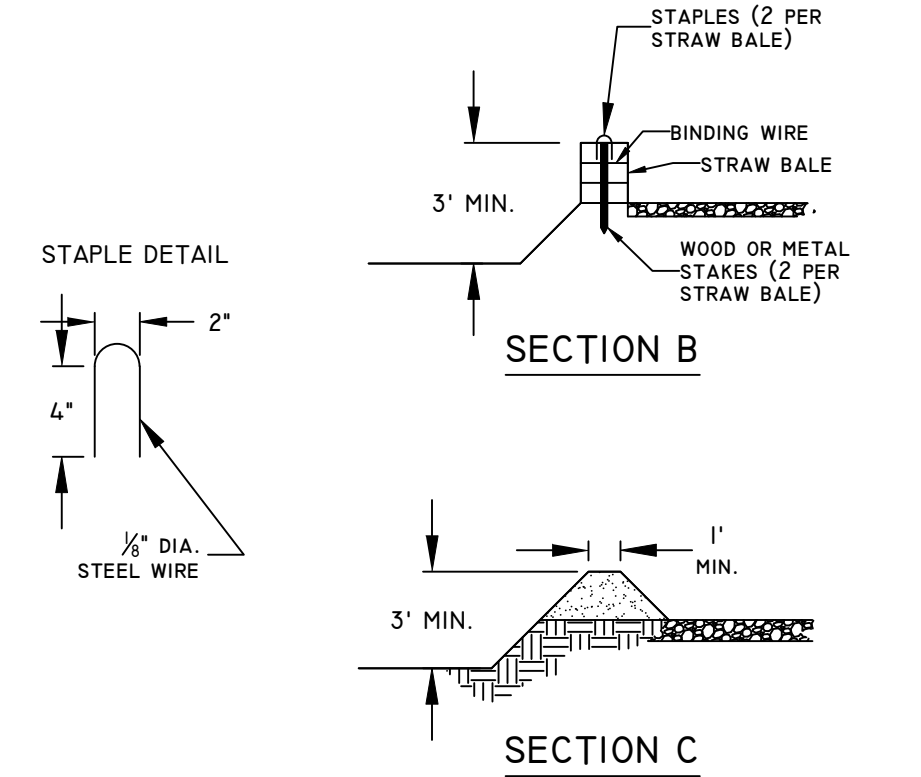
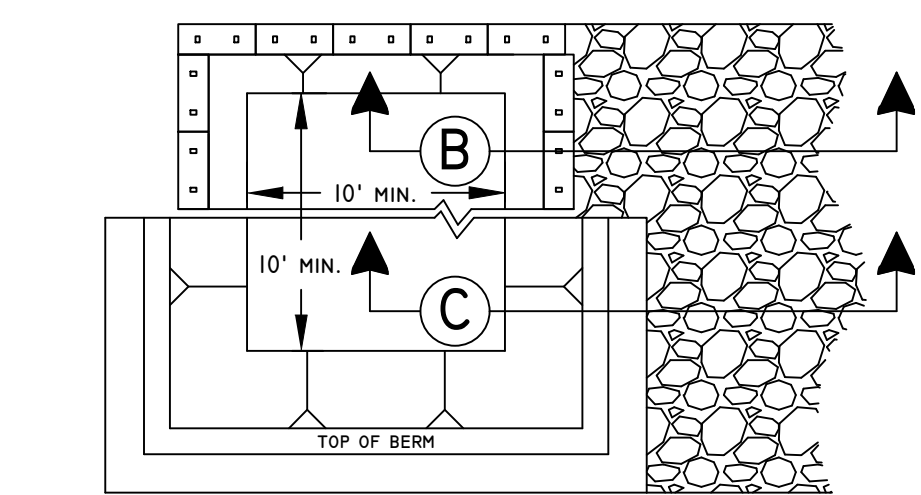

**CONCRETE WASHOUT AREA NOTES**

- The facility must be lined with 10 mil plastic lining that is free from holes, tears, or other defects that might compromise the material's impermeability.
- The lining must be anchored with staples (2" spacing) or sandbags.
- Side slopes must be 1:1 (horizontal:vertical) or flatter.
- Stone access must be provided between the street and the concrete washout area.
- A "Concrete Washout" sign must be installed within 30 feet of the washout facility. The sign must be no smaller than 2' tall by 4' wide.

**DISCHARGES OF SOAPS, DETERGENTS, SOLVENTS, AND WASH WATER FROM CONSTRUCTION ACTIVITIES SUCH AS CLEANUP OF STUCCO, PAINT, FORM RELEASE OILS, AND CURING COMPOUNDS**

- Washing activities associated with construction activities other than vehicle and equipment washing, such as clean up of stucco, paint, form release oils, and curing compounds are to be conducted in a **dedicated area**.
- The **dedicated area** must be located to maximize the distance from storm drain inlets, ditches, waterbodies or wetlands but no less than 50 feet from those features. Separations of less than 50 feet may be approved by the Environmental Inspector.
- The **dedicated areas** must be designed to prevent the discharge of soaps, detergents, solvents, and wash water.

Date	Shown on Plan Sheet # (s)	Location(s) of Dedicated Area(s)	
Approved Plan	2D(8)	Location No. 6	
REVISIONS TO LOCATIONS			
Date	Shown on Plan Sheet # (s)	Location(s) of Dedicated Area(s)	Operator(s) Initials

- The **dedicated area** must be covered (e.g., plastic sheeting, temporary roof, etc.) to prevent contact with stormwater.
- The contaminated wastewater from the **dedicated area** must be collected for disposal by a waste hauler or discharged to the sanitary sewer.
- In situations where these pollutants are or could be generated at locations other than the **designated area** (e.g., concrete pours, building washing, etc.), cover (e.g., plastic sheeting, temporary roof, etc.) must be provided to prevent contact with stormwater and the contaminated wastewater from the activity must be collected for disposal by a waste hauler or discharged to the sanitary sewer.

**DISCHARGES OF HAZARDOUS, TOXIC, AND SANITARY WASTE**

- Storage and disposal of hazardous, toxic and sanitary wastes are to be conducted in **dedicated areas**.
- The **dedicated areas** must be located to maximize the distance from storm drain inlets, ditches, waterbodies or wetlands but no less than 50 feet from those features. Separations of less than 50 feet may be approved by the Environmental Inspector.
- The **dedicated areas** must be designed to prevent the discharge of hazardous, toxic and sanitary waste by avoiding contact with precipitation.
- Each facility must have appropriate signage to inform users where the **dedicated area(s)** are located.

Date	Shown on Plan Sheet # (s)	Location(s) of Dedicated Area(s) for storage and disposal of hazardous and toxic wastes	
Approved Plan	2D(8)	Location No. 7	
REVISIONS TO LOCATIONS			
Date	Shown on Plan Sheet # (s)	Location(s) of Dedicated Area(s) for storage and disposal of hazardous and toxic wastes	Operator(s) Initials

Date	Shown on Plan Sheet # (s)	Location(s) of Dedicated Area(s) for portable toilets	
Approved Plan	2D(8)	Location No. 8	
REVISIONS TO LOCATIONS			
Date	Shown on Plan Sheet # (s)	Location(s) of Dedicated Area(s) for portable toilets	Operator(s) Initials

- Consult with local waste management authorities or private firms about the requirements for disposing of hazardous materials and/or soils that may be contaminated with hazardous materials.
- Never remove the original product label from the container. Follow the manufacturer's recommended method of disposal.
- Schedule periodic pumping of portable toilets and dispose of waste.
- Dispose of all solid waste at an authorized disposal site.

**SWPPP MODIFICATIONS AND REVISIONS**

- The operator(s) shall ensure the SWPPP is modified and/or revised to reflect:
  - Changes in qualified personnel, delegated authorities or other personnel required as a condition of the General Construction Permit;
  - Changes in site conditions;
  - Changes in the design, construction, operation, or maintenance of the construction site that affect the potential for discharge of pollutants that are not addressed in the normal implementation of the plan; and
  - Ineffective control measures identified during inspections or investigations conducted by the operator's qualified personnel or local, state or federal officials.

Modifications/revisions to the SWPPP shall include additional or modified control measures to address the identified deficiencies.

If the necessary modifications/revisions require approval by the Administrator or DEQ, the modifications/revisions must be implemented no later than seven (7) calendar days following approval.

If the necessary modifications/revisions do not require approval by the Administrator, the modifications/revisions must be implemented prior to the next anticipated storm event or as soon as practicable.

**SWPPP UPDATES**

- The operator(s) shall update the SWPPP to include:
  - A record of dates when 1) major grading activities occur, 2) construction activities temporarily or permanently cease on a portion of the site, and 3) stabilization measures are initiated;
  - Documentation of modifications and revisions to the SWPPP;
  - Areas that have reached final stabilization where no further SWPPP or inspection requirements apply;
  - All properties that are no longer under the legal control of the operator and the dates on which the operator no longer had legal control over each property; and
  - The date, volume, and corrective/preventative actions implemented for any prohibited discharge.

The operator(s) shall update the SWPPP no later than seven (7) days following any of the situations identified above.

**OPERATOR INSPECTIONS**

The operator(s) identified below shall provide for inspections of the permitted land-disturbing activities by the qualified personnel identified below. The inspections will be conducted (select one the following options):

- at least once every four (4) business days; or
- at least once every five (5) business days and no later than 48 hours following any measurable storm event.

Where areas are in a stabilized condition or runoff is unlikely due to winter conditions, the inspection frequency may be reduced to once every 30 days while these conditions exist. Otherwise, the operator(s) shall resume the regular inspection frequency identified above.

The operator(s) shall provide for inspections of the permitted land-disturbing activity to ensure implementation and continued maintenance of all requirements of the Stormwater Pollution Prevention Plan (Erosion and Sediment Control Plan, Stormwater Management Plan, Pollution Prevention Plan, TMDL requirements, etc.).

Records of the required inspections must be maintained and included in the SWPPP binder. The qualified personnel are encouraged to use the Operator Inspection form provided in the SWPPP binder to document the required inspections. If inspections are conducted once every five (5) business days and no later than 48 hours following any measurable storm event, the location of the rain gauge used to determine the amount of rain must be included in the SWPPP and documented in the inspection report.

**ACKNOWLEDGEMENTS**

I certify under penalty of law that the qualified personnel identified below:

- has been designated by the Operator to conduct inspections of the permitted site;
- is knowledgeable in the principles and practices of erosion and sediment control and stormwater management;
- possesses the skills to assess conditions at the permitted site for the Operator(s) that could impact stormwater quality and quantity;
- will assess the effectiveness of any erosion and sediment control measures or stormwater management facilities selected to control the stormwater discharges from the permitted site; and
- will conduct inspections in accordance with the frequency noted above in the OPERATOR INSPECTIONS section of this sheet.

QUALIFIED PERSONNEL	
Name (print)	
Phone	
Additional information is located in Tab 6 of the SWPPP Binder.	

As the Operator(s) or Delegated Authority, I/we understand that prior to initiating land disturbance, the potential pollutant sources, appropriate control measures and all responsible parties (operator, qualified inspection personnel, contractors, etc.) required as a condition of the General Construction Permit (GCP) and the Stormwater Pollution Prevention Plan (SWPPP) must be identified. I also understand this information must be updated as necessary throughout all phases of construction until the GCP is terminated.

Furthermore, I/we certify under penalty of law that I/we have read and understand all requirements of the SWPPP (erosion and sediment control plan, stormwater management plan, pollution prevention plan, TMDL provisions, administrative requirements, etc.) and GCP and that the information herein is, to the best of my knowledge and belief, true, accurate, and complete. I am aware that there are significant penalties for submitting false information, including the possibility of fine or imprisonment for knowing violations.

I/we understand that I/we are ultimately responsible for compliance with all conditions and requirements of the SWPPP and GCP and for ensuring all contractors and subcontractors on the permitted site are aware of the conditions and requirements of the SWPPP and GCP.

I/we shall comply with all conditions and requirements of the SWPPP and shall at all times properly operate and maintain all measures and control (and related appurtenances) which are installed or used to achieve compliance with the conditions of the GCP. Proper operation and maintenance also includes adequate funding and adequate staffing.

I/we shall take all reasonable steps to minimize or prevent any discharge in violation of the SWPPP and/or GCP.

I/we understand that if it determined by the Department of Environmental Quality (DEQ) in consultation with the State Water Control Board at any time that stormwater discharges are causing, have reasonable potential to cause, or contribute to and excursion above any applicable water quality standard, the DEQ may, in consultation with the Administrator, take appropriate enforcement action and require:

- Modification of control measures to adequately address water quality concerns;
- Submission of valid and verifiable data and information that are representative of ambient conditions and indicate that the receiving water is attaining water quality standards; or
- Cessation of discharges of pollutants from construction activity and submit an individual permit application according to 4VAC25-870-410.

OPERATOR(S) / DELEGATED AUTHORITY		
Name (print)	Signature	Date

Additional contact information can be found in the SWPPP Binder.

**POLLUTION PREVENTION PLAN**

COUNTY OF HENRICO  
DEPARTMENT OF PUBLIC WORKS



YOUR VISION ACHIEVED THROUGH OURS.

THIS DRAWING PREPARED AT THE  
CORPORATE OFFICE:  
1001 Boulevard Park  
Tel: 804.200.6500 FAX: 804.560.1016 www.timmons.com

DATE	REVISION DESCRIPTION
6/30/2019	

**TIMMONS GROUP**

Site Development | Residential | Infrastructure | Technology  
EAST RAMP 3 ACCESS ROAD  
HENRICO COUNTY - VIRGINIA  
POLLUTION PREVENTION PLAN

JOB NO.	40930.001
SHEET NO.	02G

These plans and associated documents are the exclusive property of TIMMONS GROUP and may not be reproduced, in whole or in part, and shall not be used for any purpose whatsoever, inclusive, but not limited to construction, bidding, and/or construction staging without the express written consent of TIMMONS GROUP.